



MODEL ZEPHAIRE-G
Full-size Gas Convection Oven



ZEPHAIRE-G

Project _____

Item No. _____

Quantity _____

Refer to operator manual specification chart for listed model name.

Extra depth baking compartment - accepts five 18" x 26" standard full-size baking pans in left-to-right or front-to-back positions.

All data is shown per oven section, unless otherwise indicated.

Refer to operator manual specification chart for listed model name.

EXTERIOR CONSTRUCTION

- Full angle iron frame
- Stainless steel front, top, and sides
- Solid dependent stainless steel doors
- Porcelain door handle with simultaneous door operation
- Triple-mounted pressure lock door design with turnbuckle assembly
- Removable front control panel
- Solid mineral fiber insulation at top, back, sides and bottom

INTERIOR CONSTRUCTION

- Double-sided porcelainized baking compartment liner (14 gauge)
- Aluminized steel combustion chamber
- Dual inlet blower wheel
- Five chrome-plated racks, eleven rack positions with a minimum of 1-5/8" (41mm) spacing

OPERATION

- Dual Flow Gas system combines direct and indirect heat
- Electronic spark ignition control system
- Removable dual tube burners
- Pressure regulator and manual gas service cut-off valve located in front control area
- Air mixers with adjustable air shutters
- Solid state thermostat with temperature control range of 200°F (93°C) to 500°F (260°C)
- Single speed fan motor
- 1/3 horsepower blower motor with automatic thermal overload protection
- Control area cooling fan

STANDARD FEATURES

- Solid state manual controls with separate dials for thermostat and timer
- 25" (635mm) adjustable stainless steel legs (for single units)
- 6" (152mm) adjustable stainless steel legs (for double sections)
- 60 minute electric timer with buzzer
- One year parts and labor oven warranty*
- Three year limited oven door warranty*

* For all international markets, contact your local distributor.

OPTIONS AND ACCESSORIES

(AT ADDITIONAL CHARGE)

- **Legs/casters:**
 - 6" (152mm) seismic legs
 - 6" (152mm) casters
 - 4" (107mm) low profile casters
 - 25" (635mm) stainless steel open stand with rack guides
- **Venting:**
 - Draft diverter
 - Draft hood
- **Gas hose with quick disconnect and restraining device:**
 - 48" (1219mm) hose
 - 36" (914mm) hose
- Extra oven racks
- Gas manifold (for double sections)
- Stainless steel solid back panel
- Plus package (glass doors, interior lights and a two speed motor)
- Flue connector
- Extended warranty



BLODGETT OVEN COMPANY

www.blodgett.com

44 Lakeside Avenue, Burlington, VT 05401

Toll Free: (800) 331-5842 • Phone: (802) 860-3700 • Fax: (802) 864-0183



MODEL ZEPHAIRE-G

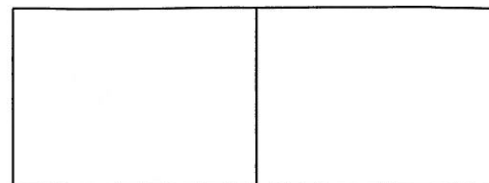

APPROVAL/STAMP

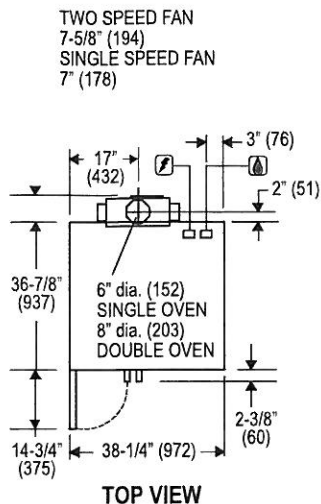

TOP VIEW

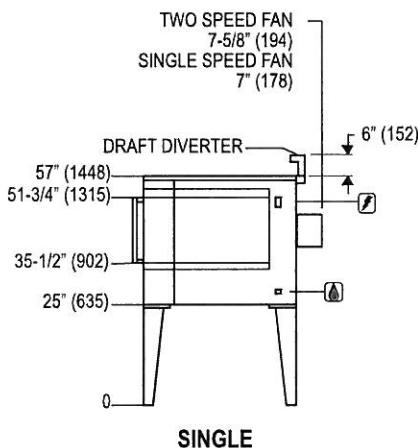

SINGLE

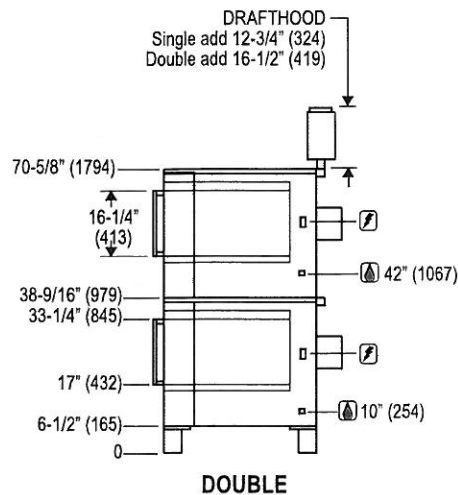

DOUBLE

Dimensions are in inches (mm)

SHORT FORM SPECIFICATIONS

Provide Blodgett full-size convection oven model ZEPHAIRE-G, (single/double) compartment. Each compartment shall have porcelainized steel liner and shall accept five 18" x 26" standard full-size bake pans in left-to-right or front-to-back positions. Doors shall be solid stainless steel with porcelain door handle and simultaneous door operation. Unit shall be gas heated with electronic spark ignition and shall cook by means of a dual-flow system combining direct and indirect heat. Air in baking chamber distributed by dual inlet blower wheel powered by a single-speed, 1/3 HP motor with thermal Overload protection. Each chamber shall be fitted with five chrome-plated removable racks. Control panel shall be recessed with Cook/Cool Down mode selector, solid slate manual infinite thermostat (200 - 500°F), and 60-minute timer. Provide options and accessories as indicated.

DIMENSIONS:

- Floor space** 38-1/4" (972mm) W x 36-7/8" (936mm) L
- Product clearance** 6" from combustible and non-combustible construction.
- Interior** 29" (737mm) W x 20" (508mm) H x 28-1/4" (718mm) D
- If oven is on casters add to all height dimensions:**
- Single 4-1/2" (114mm)
- Double 2-1/4" (57mm)

GAS SUPPLY:

- 3/4" IPS connection at rear of oven
- Manifold Pressure:
 - Natural – 3.5" W.C.
 - Propane – 10" W.C.
- Inlet Pressure:
 - Natural – 7.0" W.C. min. – 10.5" W.C. max.
 - Propane – 10.5" W.C. min. – 13.0" W.C. max.

MAXIMUM INPUT:

- Single 60,000 BTU/hr (17.6 Kw)
- Double 120,000 BTU/hr (35.2 Kw)

POWER SUPPLY:

- 115 VAC, 1 phase, 6 Amp, 60 Hz., 2-wire with ground, 1/3 H.P., 1 speed motor, 1725 RPM (two speed optional)
- 230, 220/240VAC, 1 phase, 3 Amp, 50 Hz., 2-wire with ground, 1/3 H.P., 1 speed motor, 1425 RPM
- 6' (1.8m) electric cord set furnished on 115 VAC ovens only.

MINIMUM ENTRY CLEARANCE:

- Uncrated 32-1/16" (814mm)
- Crated 37-1/2" (953mm)

SHIPPING INFORMATION:

- Approx. Weight:**
- Single: 640 lbs. (290 kg)
- Double: 1245 lbs. (565 kg)
- Crate sizes:**
- 37-1/2" (952mm) x 43-1/2" (1105mm) x 51-3/4" (1315mm)

NOTE: The company reserves the right to make substitutions of components without prior notice

BLODGETT OVEN COMPANY

www.blodgett.com

44 Lakeside Avenue, Burlington, VT 05401 Toll Free: (800) 331-5842 • Phone: (802) 860-3700 • Fax: (802) 864-0183