

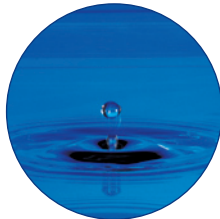

WastePro food waste dewaterers are part of our comprehensive range of waste disposal equipment for use in all commercial kitchens. To find out more please visit our website or contact our sales team.



IMC was founded in 1906 and has since established itself as a leading manufacturer of catering and bar equipment, with a reputation for quality, innovation and unrivalled customer service.



We have the resources, manufacturing expertise, knowledge and skills to provide you with complete waste management and catering solutions and to offer custom built equipment, all of which is designed and manufactured in an ISO9001 approved environment.

### Imperial Machine Company Limited

Unit 1 Abbey Road  
Wrexham Industrial Estate  
Wrexham  
LL13 9RF  
United Kingdom

Tel: +44 (0)1978 661155  
Fax: +44 (0)1978 729990  
Email: fwd@imco.co.uk  
www.imc-fwd.co.uk





## **Waste Dewaterers**

Kitchen hygiene with style and functionality

**imc**  
fresh thinking

## How IMC Food Waste Dewaterers Work

IMC dewaterers are ideal for kitchens where food waste cannot be disposed of via mains drainage, either due to technical restrictions or local regulations.

IMC dewaterers are manufactured in the UK to the highest standards, offering an excellent combination of reliability, performance and durability. IMC dewaterers are WRAS approved and CE marked.

### Operator Safety

The discharge chute features a safety interlock to prevent access to the working parts while the unit is operating.

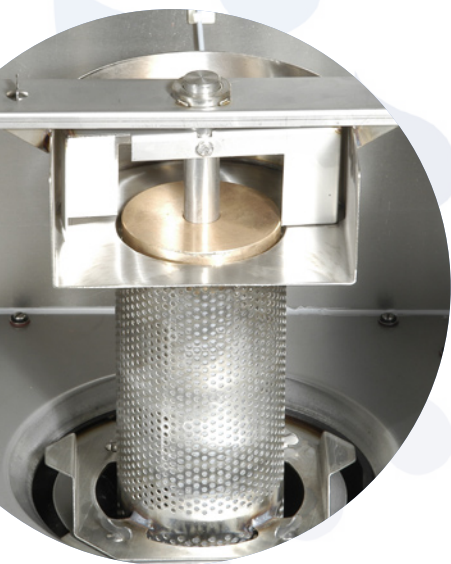

Food preparation and table waste is fed into the food waste disposer and ground into fine pieces. These are automatically washed into the dewaterer and the excess liquid pressed out. Solid waste is expelled into a bin from the discharge chute. Liquids are flushed down the drain or recirculated in the system.

### Reduce Costs

Food waste is reduced in volume by up to 80%. This significantly reduces food waste handling, storage and collection costs.

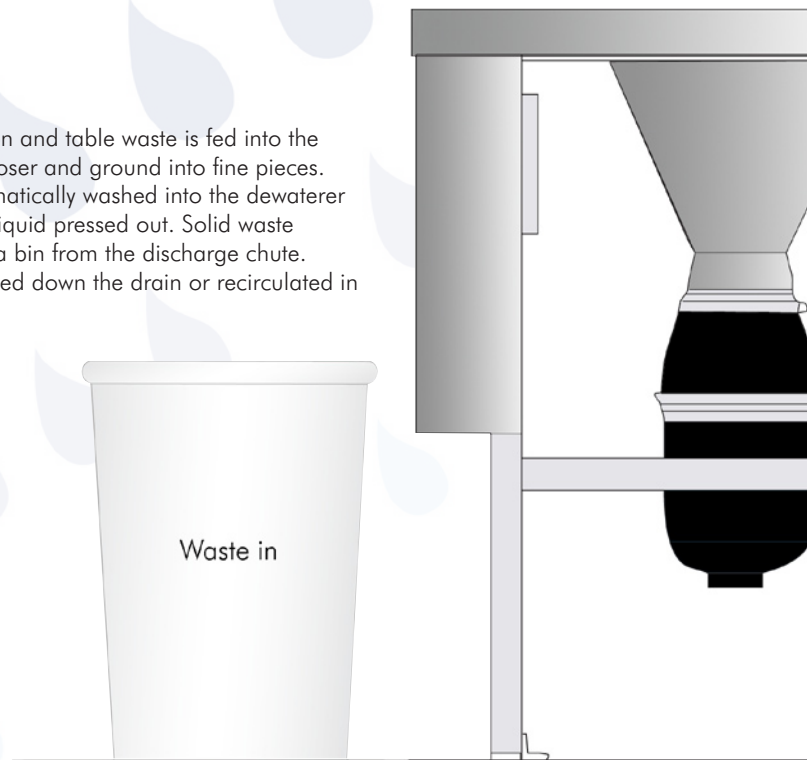

### Waste Collection

Robust waste collection bins available with secure transparent lid and strong carrying handle.



### Quick and Hygienic

Food waste for over 1000 covers per sitting can be processed, helping to reduce the amount of waste stored, eliminate unpleasant odours and improve kitchen hygiene.



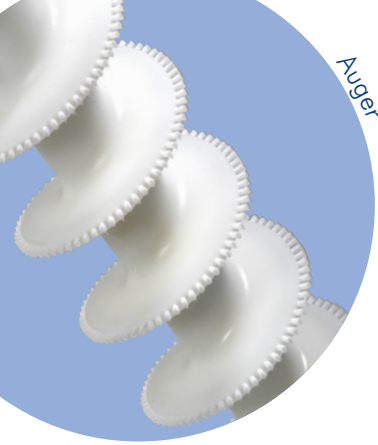

Auger

**Easy To Install and Low Maintenance**

IMC dewaterers are quick and easy to install and can be configured for left or right handed installation.

Maintenance is minimal and can be carried out easily as the unit is quick to disassemble without the need for special tools



Discharge Chute

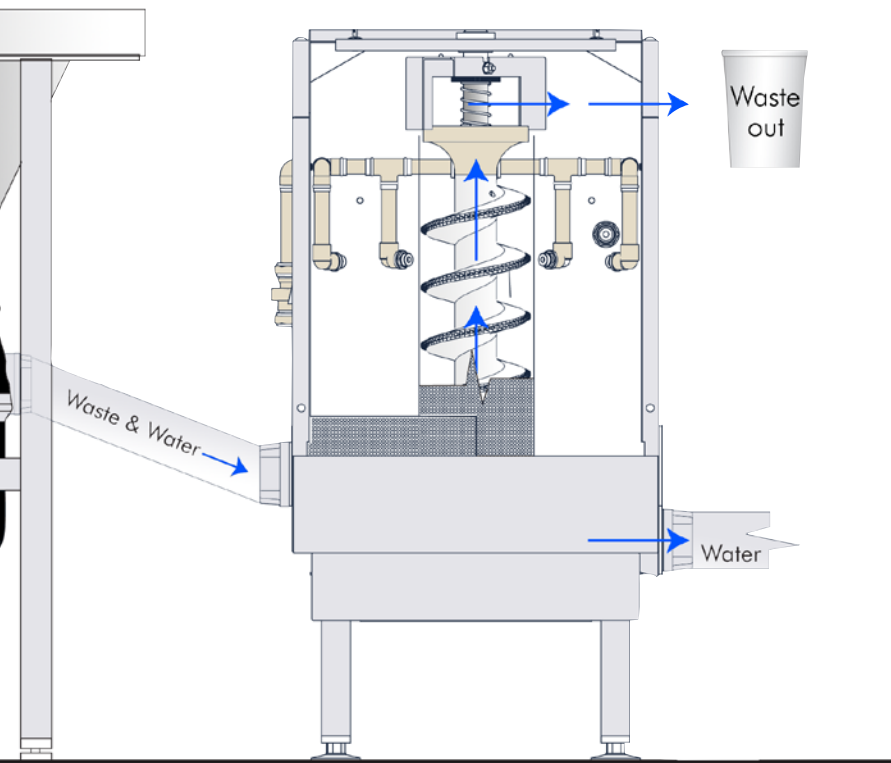

**Easy To Clean**

Constructed of hygienic stainless steel, cleaning is quick and simple and requires no tools. The auger and screen can easily be removed for cleaning in a dishwasher, allowing the inside of the unit to be hosed down.

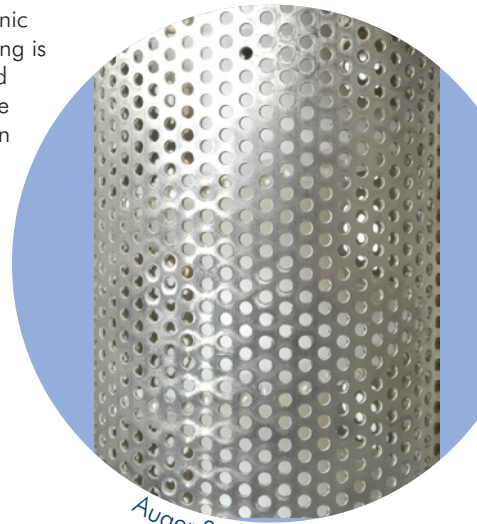

Auger Screen

The IMC waste dewaterer systems reduce waste volume by up to 80%

**Compact Design**

WastePro can be situated under new or existing tabling due to its small size and adjustable feet, making it ideal for use in kitchens where space is at a premium.

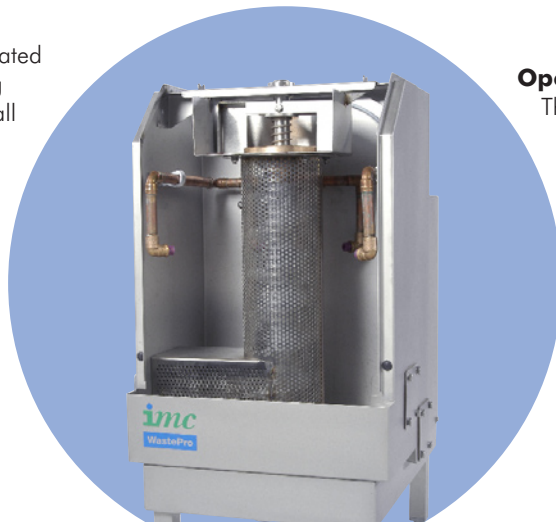

**Operator Controls**

The dewaterers are fully automatic and interlinked with the food waste disposer to start and stop automatically.

**WRAS**  
APPROVED  
PRODUCT

## WastePro - Improve Hygiene & Reduce Costs

The IMC WastePro dewaterer offers excellent levels of durability, reliability and performance for kitchens serving up to 1450 meals per sitting.

Combined with a food waste disposer, WastePro deals with food waste at source, efficiently reducing waste volume by up to 80%. This offers significantly reduced food waste collection costs.

WastePro is simple to use, and offers low levels of maintenance. Cleaning is extremely quick and easy, as the auger and auger screen can be quickly disassembled without tools for cleaning in a dishwasher and the inside of the unit hosed down.

Quick and easy to install, WastePro has compact dimensions and a small footprint. WastePro can be situated under new or existing tabling and in kitchens where space is at a premium.

WastePro is fully compatible with IMC food waste disposers from 1.1kW (1.5HP) up to 2.2kW (3HP), (excluding the O4X Series).

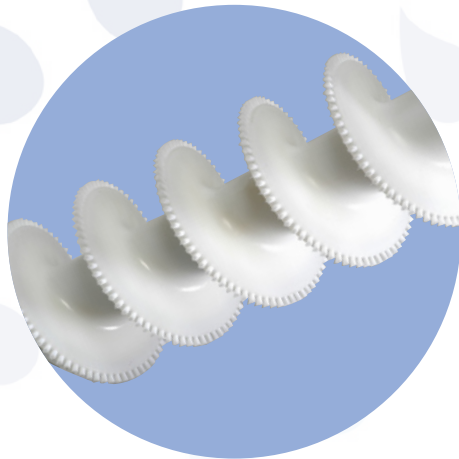

### WastePro

Mounting	Under bench or free standing
Capacity	Up to 1450 covers per sitting 700kg of waste per hour (dependent on food waste disposer)
Motor	0.37kW (0.5HP)
Fuse rating	16A - 1 phase or 6A - 3 phase
Operator controls	Automatic - wired to food waste disposer controls
Water control	Automatic water control
Operator safety	Discharge chute safety interlock
Features	Hygienic Stainless steel construction Quick and easy to dismantle for cleaning Waste inlet and waste water outlet can be left or right handed Adjustable height

For more information see technical specification leaflet  
Marine voltages available  
Capacities are approximate and may vary depending on the mix of waste types

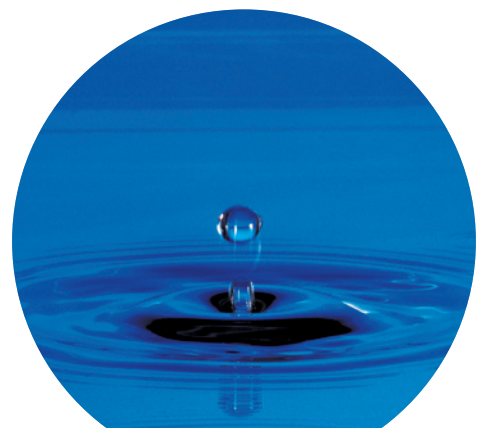

## SYS2000 - The All-In-One Solution

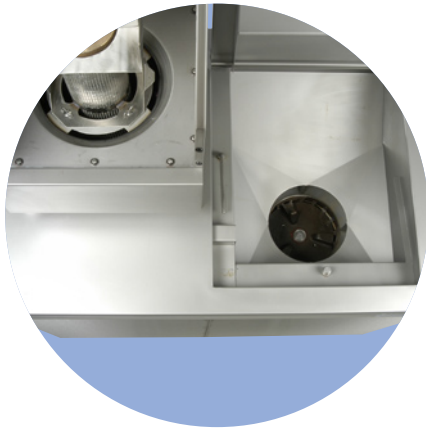

SYS2000 is the all in one solution for medium to large kitchens, especially in areas where water supplies are limited or metered. The SYS2000 combines a powerful food waste disposer with a highly effective dewaterer.

Designed to handle up to 450kg of waste per hour, the SYS2000 is capable of reducing solid food waste volume by up to 80%.

Easy to operate, the SYS2000 has an intelligent control system to monitor the fully automatic operation. After switching on, the system fills with water to the correct levels. The motor automatically starts and the unit can then be operated.

Water from the dewatering process is automatically recycled within the unit, limiting water consumption and considerably cutting the cost of metered water.

Cleaning is simple as the auger and screen can be easily disassembled without tools for cleaning in a dishwasher and the inside of the unit hosed down.

Safety baffles and an interlock system on the disposer hopper and waste chute guarantees complete operator safety.



### SYS2000

Mounting	Free standing
Capacity	Up to 900 covers per sitting 450kg of waste per hour
Motor	Disposer motor 4.0kW (5.5HP) Dewaterer motor 1.1kW (1.5HP)
Fuse rating	16A - 3 phase
Operator controls	IP65 rated waterproof wall mounted control box
Water control	Automatic water control Automatic system fill Automatic recirculation Manual water drain
Operator safety	Metal baffle and time delayed interlock system Discharge chute safety interlock
Features	Recirculation process conserves water Quick and easy to dismantle for cleaning Magnetic cutlery saver Automatically reversible motor for extended life Automatic thermal overload to protect motor Trickle water feed Hygienic stainless steel construction
Options	Front, back or side chute positions Provision to connect to scrapping trough IP65 rated integral controls Sanitising kit for continual disinfection

For more information see technical specification leaflet

Marine voltages available

Capacities are approximate and may vary depending on the mix of waste types

## Peace of mind guaranteed

### Peace Of Mind Guaranteed

IMC is a leading supplier of commercial food waste disposers and dewaterers.

Our products are used throughout the catering sector – from street corner cafés to Michelin star restaurants, and from schools and prisons to hospitals and nursing homes.

We are renowned for quality, reliability and innovation, with a reputation for customer service and support that gives you total peace of mind every time you choose an IMC product.

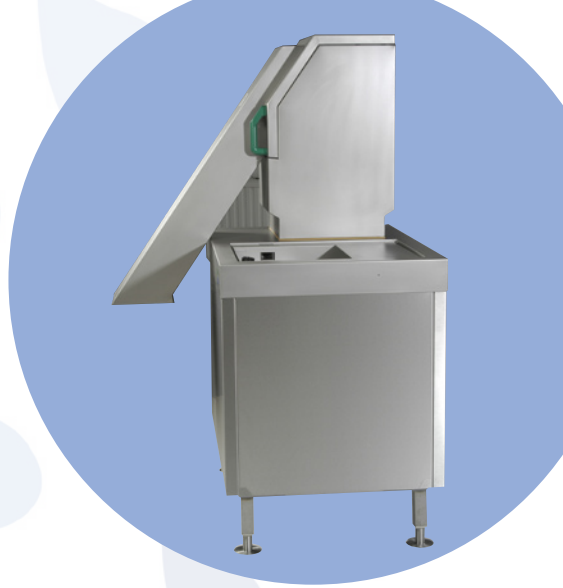

### SYS2000 Operational Diagram

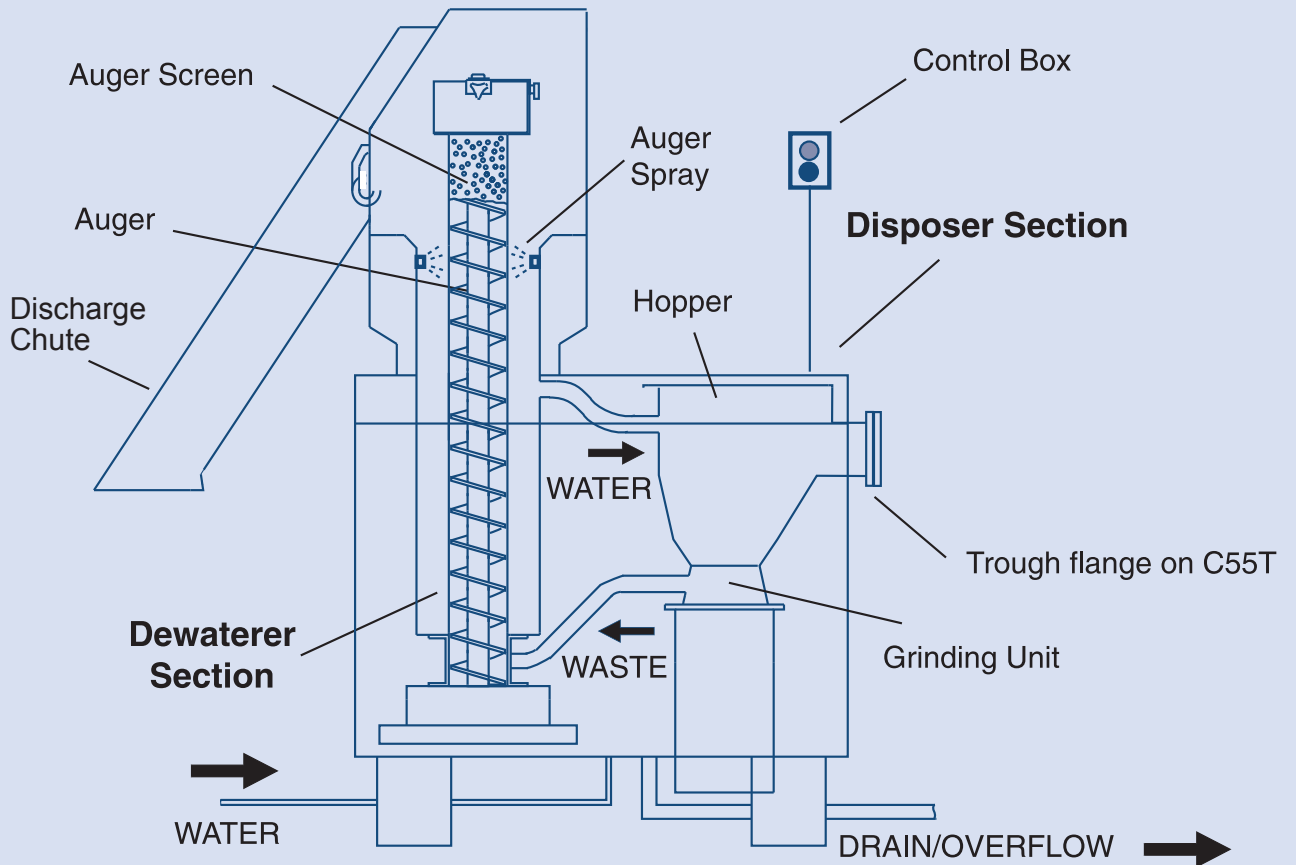



## WastePro Dimensions

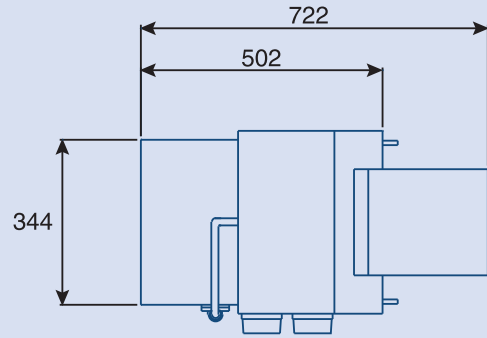

Plan View

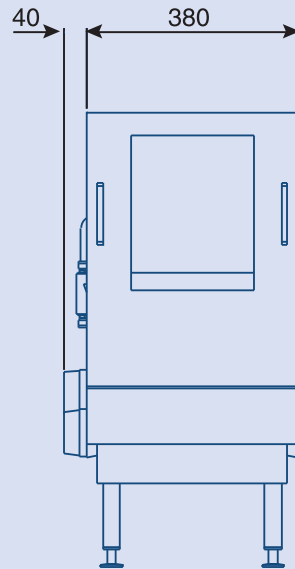

Front View

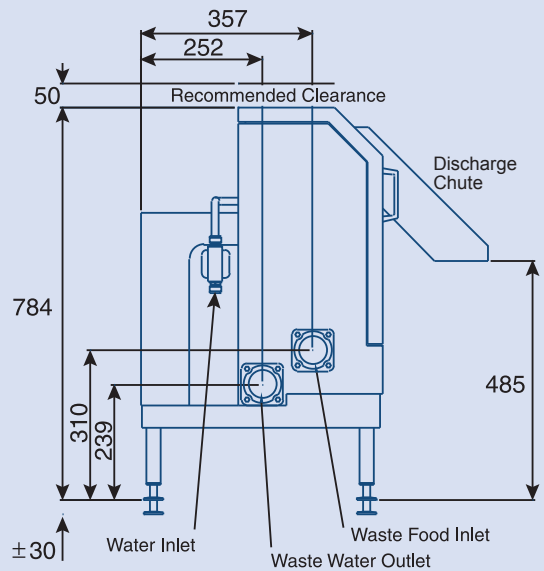

Side View

## SYS2000 Dimensions

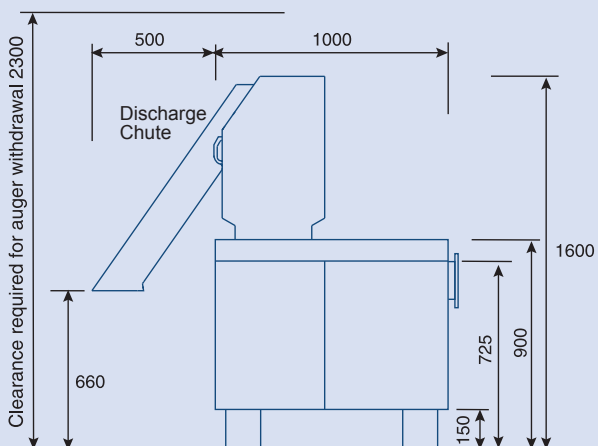
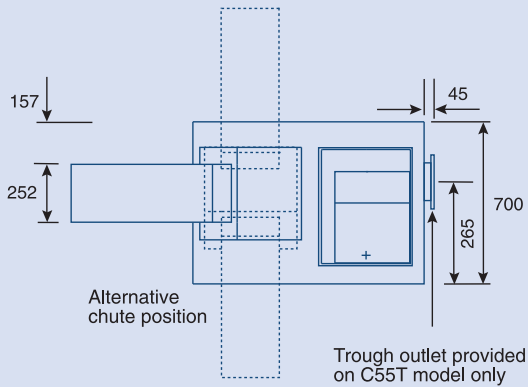
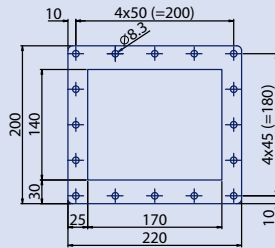

Clearance required for auger withdrawal 2300